



## **RING TYPE JOINT GASKETS**

*Flexitallic*™







## **GLOBAL RESOURCE**

FLEXITALLIC, A WORLDWIDE ORGANIZATION

## **LOCAL SERVICE**

COMMITTED TO MEETING CUSTOMER NEEDS

## **COMPREHENSIVE PRODUCT RANGE**

FOR ALL INDUSTRIAL AND PETROCHEMICAL APPLICATIONS  
LET FLEXITALLIC TAKE THE PRESSURE

## **SEALING SOLUTIONS**

THE ANSWER IS ALWAYS FLEXITALLIC

*Flexitallic*<sup>®</sup>



---

## ABOUT US

---

**The Flexitallic Group is the international market leader in the manufacture and supply of high quality, high value sealing products.**

Based on sales and geographic reach, The Flexitallic Group is the only true global supplier of industrial gaskets. The company maintains a major market position in all pressure ranges of static sealing devices used throughout the world, most notably in the oil and gas industry's upstream and downstream operations.

Our global expertise, combined with local availability, ensures that our customers benefit from first class products, together with outstanding customer service and technical support. We provide a comprehensive range of semi-metallic gaskets, sheet gasket materials, pump and valve seals and metallic gaskets to a wide range of oil and gas, industrial, pulp and paper, and automotive customers. Specialist markets include refining petrochemicals, power generation, food, pharmaceutical, marine, offshore and water treatment markets.



Flexitallic is skilled at providing design and development work to help customers build optimum solutions. We have created some important product leaders in the sealing industry such as Thermiculite, material for high temperature, high pressure applications and Sigma, a PTFE based sheet designed to seal in the harshest chemical environments.

With an ongoing investment in high technology, we are well-equipped to develop innovative and reliable new products.

At all locations, trained technical staff answer product enquires, solve problems and provide 24 hour emergency assistance anywhere in the world.





---

## ABOUT US

---



### WORLDWIDE REPUTATION

Flexitallic has been at the forefront of sealing technology for over 100 years. During this time the company has gained an unrivalled reputation as a global supplier of quality products and services.

An ethos of continuous development and improvement of products and services coupled with close attention to local market needs, ensures the Company's status as a worldwide market leader way into the future.

### RESEARCH AND DEVELOPMENT

The dynamic needs of the market place can only be satisfied by manufacturers who are prepared to invest in research and development. Flexitallic works continuously to supply industry with the most advanced products and sealing solutions.

### PRODUCT RANGE

The ability of a product to meet the requirements of a dynamic market place is key to the success of any company. Flexitallic has the ability to supply the world's industries with an unparalleled range of products and services - "The Total Sealing Solution".

Flexitallic manufactures a full range of metallic static seals, they are manufactured in types R, oval and octagonal cross-sectional profiles, along with RX, BX, SRX and SBX.

Flexitallic manufactures a full range of metallic static seals. These are available as ring type joint gaskets (page 5), welded membrane gaskets (page 15), and weld ring gaskets (page 15).

All Flexitallic's products are manufactured to the highest quality standards ensuring fitness for purpose with the added convenience of the support of global supply.



*Extensive stocking*

## **TECHNICAL SUPPORT AND CUSTOMER SERVICE**

The company's command of its technology provides a sound basis for technical and commercial customer support. Qualified engineers are always available for technical audits, advice on specifications or troubleshooting, while every sales office has a full team of staff to deal with technical or sales enquires by telephone, fax, or e-mail.

The "customer ethic" is central to Flexitallic's philosophy and this is a part of the global strategy which is apparent in every Flexitallic business throughout the world.



## **PRODUCT SELECTION**

Increasing environmental and economic pressures require that the most suitable product be used in every application. This brochure is intended to aid the process of product selection.

If you require more detailed information to ensure compatibility, please consult Flexitallic's Technical Department who will be pleased to assist.

## **COMPANY STATEMENT**

### **The Products**

Flexitallic designs and manufactures all its products under a quality system which is accredited to BS EN ISO 9001. The operating mission is to produce an unrivalled level of excellence in product specification, performance and availability.

### **The Environment**

In the design and manufacture of its products Flexitallic gives full consideration to environmental concerns. By supplying cost effective and proven sealing products to industry the company contributes not only to greater productivity and reduced downtime, but also to the control and prevention of fugitive emissions.



*All products are designed and manufactured under stringent quality controls*

## QUALITY ASSURED MANUFACTURING

All Flexitallic Ring Type Joints are manufactured from fully traceable materials and are supplied to NACE specifications upon request. Each Ring Type Joint is identified by low stress stamping with style, ring number, API license number, material reference, Product Specification Level (PSL), a unique Flexitallic material identification number, and month and year of manufacture. Such full and comprehensive traceability, from material source with mill certification to final supply, is an essential ingredient in the company's strict quality assurance procedures and exceeds those demanded by the highest API 6A PSL 4.

### MATERIALS

The gasket material should be selected to suit the service conditions. It is always recommended that the gasket material be softer than the mating flanges. The more popular Ring Type Joint materials, with the recommended maximum hardness and identification as specified in API 6A, are shown in the table below.

For more highly specialized applications, Ring Type Joints can be machined from DUPLEX steels and other exotic materials such as Monel®, Inconel®, Incoloy®, and Hastelloy®. The Technical Department is available to advise on other materials.



*Low Stress stamping for identification and traceability*

### PROTECTIVE COATING

In accordance with API Specifications, soft iron and low carbon steel Ring Type Joints are protected with electroplated zinc to a maximum thickness of 8µm. Alternative material coatings can be supplied on request.



6A-0062

MATERIAL	UNS NUMBER	MAXIMUM HARDNESS		IDENTIFICATION
		BRINELL*	ROCKWELL B†	
Soft Iron		90	56	D
Low Carbon Steel		120	68	S
4–6% Chrome 1/2% Moly	K42544	130	72	F5
Type 304 Stainless Steel	S30400	160	83	S304
Type 316 Stainless Steel	S31600	160	83	S316
Type 347 Stainless Steel	S34700	160	83	S347
Type 410 Stainless Steel	S41000	170	86	S410
Titanium Grade 2	R50400			
Alloy 600	N06600	200		
Alloy 625	N06625	200		
Alloy 800	N08800	200		
Alloy 825	N08825	160		
Hastelloy	N10001	200		
Alloy C276	N10276	200		
SMO 254	S32154	180		
Zeron 100		200		
Super Duplex	S31803			

\* Measured with 3000 Kg load except soft iron which is measured with 500 Kg load

† Measured with 100 Kg load and 1/16 inch diameter ball

# STYLE R

The Ring Type Joint was initially developed for high pressure/temperature applications found in the petroleum industry and is primarily used in the oil field on drilling and completion equipment. However, today this product range can also be found on valves and pipework assemblies, along with some high integrity pressure vessel joints.



Style R

Standard Style R Ring Type Joints are manufactured in accordance with both API 6A and ASME B16.20 size/ratings. Available in both oval and octagonal configurations, both types are interchangeable on the modern octagonal type grooved flanges.

*As with all solid metal Ring Type Joints including Style R, it is recommended to replace the ring when flange connection is broken.*

## DIMENSIONAL DATA – STYLE R

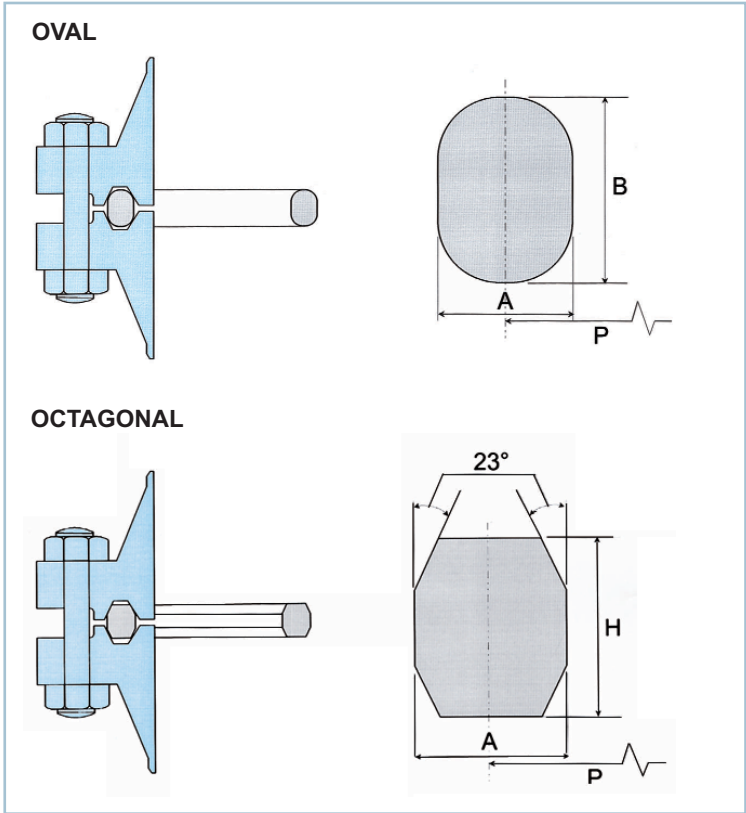

**TOLERANCES: (INCHES)**

A (width of ring)	±0.008
B, H (height of ring)	±0.020
P (average pitch diameter of ring)	±0.007
23° (angle)	±1/2°

*Flexitallic Style R Ring Type Joints can be manufactured in accordance with all relevant standards to suit the following flange designations:*

- API 6A
- ASME/ANSI B16.5
- MSS SP44 (ASME B16.47 SERIES A)
- BS 1560

# STYLE R

## Dimensions in mm

RING NO.	PRESSURE CLASS RATINGS							PITCH DIAMETER OF RING P	WIDTH OF RING A	HEIGHT OF RING		APPROX. DISTANCE BETWEEN MADE UP FLANGES	GASKET WEIGHTS, lbs.	
	ANSI, BS & MSS					API (PSI)				OVAL	OCTAGONAL		OVAL	OCTAGONAL
	150	300/600	900	1500	2500	2000/3000	5000			B	H			
	NOMINAL PIPE SIZE (INCHES)													
R11	-	1/2	-	-	-	-	-	34.13	6.35	11.1	9.5	-	.111	.104
R12	-	-	1/2	1/2	-	-	-	39.69	7.95	14.3	12.7	-	.216	.20
R13	-	3/4	-	-	1/2	-	-	42.86	7.95	14.3	12.7	-	.234	.216
R14	-	-	3/4	3/4	-	-	-	44.45	7.95	14.3	12.7	-	.242	.224
R15	1	-	-	-	-	-	-	47.63	7.95	14.3	12.7	-	.260	.24
R16	-	1	1	1	3/4	-	-	50.80	7.95	14.3	12.7	-	.278	.256
R17	1 1/4	-	-	-	-	-	-	57.15	7.95	14.3	12.7	-	.311	.288
R18	-	1 1/4	1 1/4	1 1/4	1	-	-	60.33	7.95	14.3	12.7	-	.328	.304
R19	1 1/2	-	-	-	-	-	-	65.09	7.95	14.3	12.7	-	.354	.328
R20*	-	1 1/2	1 1/2	1 1/2	-	-	-	68.28	7.95	14.3	12.7	4.1	.372	.344
R21	-	-	-	-	1 1/4	-	-	72.23	11.11	17.5	15.9	-	.660	.643
R22	2	-	-	-	-	-	-	82.55	7.95	14.3	12.7	-	.450	.415
R23*	-	2	-	-	1 1/2	2 1/16**	-	82.55	11.11	17.5	15.9	4.8	.755	.734
R24*	-	-	2	2	-	2 1/16	2	95.25	11.11	17.5	15.9	4.8	.870	.846
R25	2 1/2	-	-	-	-	-	-	101.60	7.95	14.3	12.7	-	.553	.510
R26*	-	2 1/2	-	-	2	2 9/16	-	101.60	11.11	17.5	15.9	4.8	.930	.904
R27*	-	-	2 1/2	2 1/2	-	(2 9/16)	2 9/16	107.95	11.11	17.5	15.9	4.8	1.050	.96
R28	-	-	-	-	2 1/2	-	-	111.13	12.70	19.1	17.5	-	1.255	1.23
R29	3	-	-	-	-	-	-	114.30	7.95	14.3	12.7	-	.622	.575
R30†	-	3	-	-	-	-	-	117.48	11.11	17.5	15.9	-	1.075	1.047
R31*	-	3	3	-	-	3 1/8	-	123.83	11.11	17.5	15.9	4.8	1.130	1.10
R32	-	-	-	-	3	-	-	127.00	12.70	19.1	17.5	-	1.435	1.405
R33	3 1/2	-	-	-	-	-	-	131.76	7.95	14.3	12.7	-	.718	.664
R34	-	3 1/2	-	-	-	-	-	131.76	11.11	17.5	15.9	-	1.200	1.17
R35*	-	-	-	3	-	-	3 1/8	136.53	11.11	17.5	15.9	4.8	1.250	1.21
R36	4	-	-	-	-	-	-	149.23	7.95	14.3	12.7	-	.813	.735
R37*	-	4	4	-	-	4 1/16	-	149.23	11.11	17.5	15.9	4.8	1.360	1.33
R38	-	-	-	-	4	-	-	157.16	15.88	22.4	20.6	-	2.56	2.52
R39*	-	-	-	4	-	-	4 1/16	161.93	11.11	17.5	15.9	4.8	1.480	1.44
R40	5	-	-	-	-	-	-	171.45	7.95	14.3	12.7	-	.935	.865
R41*	-	5	5	-	-	-	-	180.98	11.11	17.5	15.9	4.8	1.66	1.61
R42	-	-	-	-	5	-	-	190.50	19.05	25.4	23.9	-	4.21	4.16
R43	6	-	-	-	-	-	-	193.68	7.95	14.3	12.7	-	1.055	.975
R44*	-	-	-	5	-	-	-	193.68	11.11	17.5	15.9	4.8	1.77	1.73
R45*	-	6	6	-	-	7 1/16	-	211.14	11.11	17.5	15.9	4.8	1.93	1.88
R46*	-	-	-	6	-	-	7 1/16	211.14	12.70	19.1	17.5	4.8	2.39	2.33
R47*	-	-	-	-	6	-	-	228.60	19.05	25.4	23.9	4.1	5.06	4.99
R48	8	-	-	-	-	-	-	247.65	7.95	14.3	12.7	-	1.350	1.24
R49*	-	8	8	-	-	9	-	269.88	11.11	17.5	15.9	4.8	2.47	2.40
R50*	-	-	-	8	-	-	9	269.88	15.88	22.4	20.6	4.1	4.40	4.32
R51	-	-	-	-	8	-	-	279.40	22.23	28.6	27.0	-	8.05	8.17
R52	10	-	-	-	-	-	-	304.80	7.95	14.3	12.7	-	1.66	1.53
R53*	-	10	10	-	-	11	-	323.85	11.11	17.5	15.9	4.8	3.00	2.88
R54*	-	-	-	10	-	-	11	323.85	15.88	22.4	20.6	4.1	5.29	5.18
R55	-	-	-	-	10	-	-	342.90	28.58	36.5	34.9	-	16.23	17.04
R56	12	-	-	-	-	-	-	381.00	7.95	14.3	12.7	-	2.07	1.92
R57*	-	12	12	-	-	13 5/8	-	381.00	11.11	17.5	15.9	4.8	3.48	3.38

\* Denotes ring number specified in API 6A.  
 Nominal Pipe Sizes marked\*\* apply to class rating 2000 only.  
 Nominal Pipe Sizes in brackets apply to class rating 3000 only.  
 † Ring no. R30 is suitable for lapped flanges only.



# STYLE R

Dimensions in mm

RING NO.	PRESSURE CLASS RATINGS							PITCH DIAMETER OF RING	WIDTH OF RING	HEIGHT OF RING		APPROX. DISTANCE BETWEEN MADE UP FLANGES	GASKET WEIGHTS, lbs.	
	ANSI, BS & MSS					API (PSI)				OVAL	OCTAGONAL		OVAL	OCTAGONAL
	150	300/600	900	1500	2500	2000/3000	5000			B	H			
NOMINAL PIPE SIZE (INCHES)							P	A						
R58	-	-	-	12	-	-	-	381.00	22.23	28.6	27.0	-	11.00	11.13
R59	14	-	-	-	-	-	-	396.88	7.95	14.3	12.7	-	2.16	2.00
R60	-	-	-	-	12	-	-	406.40	31.75	39.7	38.1	-	23.10	23.50
R61	-	14	-	-	-	-	-	419.10	11.11	17.5	15.9	-	3.83	3.73
R62	-	-	14	-	-	-	-	419.10	15.88	22.2	20.6	-	6.84	6.71
R63*	-	-	-	14	-	-	-	419.10	25.40	33.3	31.8	5.6	16.20	16.67
R64	16	-	-	-	-	-	-	454.03	7.95	14.3	12.7	-	2.47	2.29
R65*	-	16	-	-	-	16 3/4**	-	469.90	11.11	17.5	15.9	4.8	4.30	4.18
R66*	-	-	16	-	-	(16)	-	469.90	15.88	22.2	20.6	4.1	7.67	7.53
R67	-	-	-	16	-	-	-	469.90	28.58	36.5	34.9	-	22.30	23.40
R68	18	-	-	-	-	-	-	517.53	7.95	14.3	12.7	-	2.82	2.60
R69*	-	18	-	-	-	-	-	533.40	11.11	17.5	15.9	4.8	4.87	4.74
R70*	-	-	18	-	-	(18)	-	533.40	19.05	25.4	23.9	4.8	11.80	11.64
R71	-	-	-	18	-	-	-	533.40	28.58	36.5	34.9	-	25.20	26.50
R72	20	-	-	-	-	-	-	558.80	7.95	14.3	12.7	-	3.04	2.81
R73*	-	20	-	-	-	21 1/4**	-	584.20	12.7	19.1	17.5	3.3	6.60	6.47
R74*	-	-	20	-	-	(20 3/4)	-	584.20	19.05	25.4	23.9	4.8	12.95	12.75
R75	-	-	-	20	-	-	-	584.20	31.75	39.7	38.1	-	33.30	35.30
R76	24	-	-	-	-	-	-	673.10	7.95	14.3	12.7	-	3.66	3.38
R77	-	24	-	-	-	-	-	692.15	15.88	22.4	20.6	-	11.30	11.10
R78	-	-	24	-	-	-	-	692.15	25.4	33.3	31.8	-	27.10	27.58
R79	-	-	-	24	-	-	-	692.15	34.93	44.5	41.3	4.8	48.70	49.75
R80	22	-	-	-	-	-	-	615.95	7.95	-	12.7	-	-	3.11
R81	-	22	-	-	-	-	-	635.00	14.29	-	19.1	-	-	8.55
R82*	-	-	-	-	-	-	-	57.14	11.11	-	15.9	4.8	-	.508
R84*	-	-	-	-	-	-	-	63.50	11.11	-	15.9	4.8	-	.564
R85*	-	-	-	-	-	-	-	79.38	12.70	-	17.5	3.3	-	.978
R86*	-	-	-	-	-	-	-	90.50	15.88	-	20.6	4.1	-	1.447
R87*	-	-	-	-	-	-	-	100.03	15.88	-	20.6	4.1	-	1.597
R88*	-	-	-	-	-	-	-	122.83	19.05	-	23.9	4.8	-	2.735
R89*	-	-	-	-	-	-	-	114.30	19.05	-	23.9	4.8	-	2.528
R90*	-	-	-	-	-	-	-	155.58	22.23	-	26.9	4.8	-	4.55
R91*	-	-	-	-	-	-	-	260.25	31.75	-	38.1	4.1	-	15.05
R92	-	-	-	-	-	-	-	228.60	11.11	17.5	15.9	-	2.07	2.02
R93	-	26	-	-	-	-	-	749.30	19.05	-	23.9	-	-	16.33
R94	-	28	-	-	-	-	-	800.10	19.05	-	23.9	-	-	17.44
R95	-	30	-	-	-	-	-	857.25	19.05	-	23.9	-	-	18.69
R96	-	32	-	-	-	-	-	914.40	22.23	-	27.0	-	-	26.65
R97	-	34	-	-	-	-	-	965.20	22.23	-	27.0	-	-	28.13
R98	-	36	-	-	-	-	-	1022.35	22.23	-	27.0	-	-	29.79
R99*	-	-	-	-	-	-	-	234.95	11.11	-	15.9	4.8	-	2.08
R100	-	-	26	-	-	-	-	749.30	28.58	-	34.9	-	-	
R101	-	-	28	-	-	-	-	800.10	31.75	-	38.1	-	-	
R102	-	-	30	-	-	-	-	857.25	31.75	-	38.1	-	-	
R103	-	-	32	-	-	-	-	914.40	31.75	-	38.1	-	-	
R104	-	-	34	-	-	-	-	965.20	34.93	-	41.3	-	-	
R105	-	-	36	-	-	-	-	1022.35	34.93	-	41.3	-	-	

\* Denotes ring number specified in API 6A.

Nominal Pipe Sizes marked\*\* apply to class rating 2000 only.

Nominal Pipe Sizes in brackets apply to class rating 3000 only.

† Ring no. R30 is suitable for lapped flanges only.

# STYLE R

Dimensions in inches

RING NO.	PRESSURE CLASS RATINGS						PITCH DIAMETER OF RING	WIDTH OF RING	HEIGHT OF RING			APPROX. DISTANCE BETWEEN MADE UP FLANGES	GASKET WEIGHTS, lbs.	
	ANSI, BS & MSS				API (PSI)				OVAL	OCTAGONAL	OVAL		OCTAGONAL	
	150	300/600	900	1500	2500	2000/3000								5000
	NOMINAL PIPE SIZE (INCHES)						P	A	B	H				
R11	—	1/2	—	—	—	—	1.344	0.250	0.44	0.38	—	.111	.104	
R12	—	—	1/2	1/2	—	—	1.563	0.313	0.56	0.50	—	.216	.20	
R13	—	3/4	—	—	1/2	—	1.688	0.313	0.56	0.50	—	.234	.216	
R14	—	—	3/4	3/4	—	—	1.750	0.313	0.56	0.50	—	.242	.224	
R15	1	—	—	—	—	—	1.875	0.313	0.56	0.50	—	.260	.24	
R16	—	1	1	1	3/4	—	2.000	0.313	0.56	0.50	—	.278	.256	
R17	1 1/4	—	—	—	—	—	2.250	0.313	0.56	0.50	—	.311	.288	
R18	—	1 1/4	1 1/4	1 1/4	1	—	2.375	0.313	0.56	0.50	—	.328	.304	
R19	1 1/2	—	—	—	—	—	2.563	0.313	0.56	0.50	—	.354	.328	
R20*	—	1 1/2	1 1/2	1 1/2	—	—	2.688	0.313	0.56	0.50	0.16	.372	.344	
R21	—	—	—	—	1 1/4	—	2.844	0.438	0.69	0.63	—	.660	.643	
R22	2	—	—	—	—	—	3.250	0.313	0.56	0.50	—	.450	.415	
R23*	—	2	—	—	1 1/2	2 1/16**	3.250	0.438	0.69	0.63	0.19	.755	.734	
R24*	—	—	2	2	—	2 1/16	3.750	0.438	0.69	0.63	0.19	.870	.846	
R25	2 1/2	—	—	—	—	—	4.000	0.313	0.56	0.50	—	.553	.510	
R26*	—	2 1/2	—	—	2	2 9/16	4.000	0.438	0.69	0.63	0.19	.930	.904	
R27*	—	—	2 1/2	2 1/2	—	(2 9/16)	4.250	0.438	0.69	0.63	0.19	1.050	.96	
R28	—	—	—	—	2 1/2	—	4.375	0.500	0.75	0.69	—	1.255	1.23	
R29	3	—	—	—	—	—	4.500	0.313	0.56	0.50	—	.622	.575	
R30†	—	3	—	—	—	—	4.625	0.438	0.69	0.63	—	1.075	1.047	
R31*	—	3	3	—	—	3 1/8	4.875	0.438	0.69	0.63	0.19	1.130	1.10	
R32	—	—	—	—	3	—	5.000	0.500	0.75	0.69	—	1.435	1.405	
R33	3 1/2	—	—	—	—	—	5.188	0.313	0.56	0.50	—	.718	.664	
R34	—	3 1/2	—	—	—	—	5.188	0.438	0.69	0.63	—	1.200	1.17	
R35*	—	—	—	3	—	—	5.375	0.438	0.69	0.63	0.19	1.250	1.21	
R36	4	—	—	—	—	—	5.875	0.313	0.56	0.50	—	.813	.735	
R37*	—	4	4	—	—	4 1/16	5.875	0.438	0.69	0.63	0.19	1.360	1.33	
R38	—	—	—	—	4	—	6.188	0.625	0.88	0.81	—	2.56	2.52	
R39*	—	—	—	4	—	—	6.375	0.438	0.69	0.63	0.19	1.480	1.44	
R40	5	—	—	—	—	—	6.750	0.313	0.56	0.50	—	.935	.865	
R41*	—	5	5	—	—	—	7.125	0.438	0.69	0.63	0.19	1.66	1.61	
R42	—	—	—	—	5	—	7.500	0.750	1.00	0.94	—	4.21	4.16	
R43	6	—	—	—	—	—	7.625	0.313	0.56	0.50	—	1.055	.975	
R44*	—	—	—	5	—	—	7.625	0.438	0.69	0.63	0.19	1.77	1.73	
R45*	—	6	6	—	—	7 1/16	8.313	0.438	0.69	0.63	0.19	1.93	1.88	
R46*	—	—	—	6	—	7 1/16	8.313	0.500	0.75	0.69	0.13	2.39	2.33	
R47*	—	—	—	—	6	—	9.000	0.750	1.00	0.94	0.16	5.06	4.99	
R48	8	—	—	—	—	—	9.750	0.313	0.56	0.50	—	1.350	1.24	
R49*	—	8	8	—	—	9	10.625	0.438	0.69	0.63	0.19	2.40		
R50*	—	—	—	8	—	9	10.625	0.625	0.88	0.81	0.16	4.40	4.32	
R51	—	—	—	—	8	—	11.000	0.875	1.13	1.06	—	8.05	8.17	
R52	10	—	—	—	—	—	12.000	0.313	0.56	0.50	—	1.66	1.53	
R53*	—	10	10	—	—	11	12.750	0.438	0.69	0.63	0.19	3.00	2.88	
R54*	—	—	—	10	—	11	12.750	0.625	0.88	0.81	0.16	5.29	5.18	
R55	—	—	—	—	10	—	13.500	1.125	1.44	1.38	—	16.23	17.04	
R56	12	—	—	—	—	—	15.000	0.313	0.56	0.69	—	2.07	1.92	
R57*	—	12	12	—	—	13 5/8	15.000	0.438	0.69	0.63	0.19	3.48	3.38	

\* Denotes ring number specified in API 6A.  
 Nominal Pipe Sizes marked\*\* apply to class rating 2000 only.  
 Nominal Pipe Sizes in brackets apply to class rating 3000 only.  
 † Ring no. R30 is suitable for lapped flanges only.

# STYLE R

## Dimensions in inches

RING NO.	PRESSURE CLASS RATINGS							PITCH DIAMETER OF RING	WIDTH OF RING	HEIGHT OF RING		APPROX. DISTANCE BETWEEN MADE UP FLANGES	GASKET WEIGHTS, lbs.	
	ANSI, BS & MSS					API (PSI)				OVAL	OCTAGONAL		OVAL	OCTAGONAL
	150	300/600	900	1500	2500	2000/3000	5000							
	NOMINAL PIPE SIZE (INCHES)							P	A	B	H			
R58	-	-	-	12	-	-	-	15.00	0.875	1.13	1.06	-	11.00	11.13
R59	14	-	-	-	-	-	-	15.625	0.313	0.56	0.50	-	2.16	2.00
R60	-	-	-	-	12	-	-	16.000	1.250	1.56	1.50	-	23.10	23.50
R61	-	14	-	-	-	-	-	16.500	0.438	0.69	0.63	-	3.83	3.73
R62	-	-	14	-	-	-	-	16.500	0.625	0.88	0.81	-	6.84	6.71
R63*	-	-	-	14	-	-	-	16.500	1.000	1.31	1.25	0.22	16.20	16.67
R64	16	-	-	-	-	-	-	17.875	0.313	0.56	0.50	-	2.47	2.29
R65*	-	16	-	-	-	16 3/4**	-	18.500	0.438	0.69	0.63	0.19	4.30	4.18
R66*	-	-	16	-	-	(16)	-	18.500	0.625	0.88	0.81	0.16	7.67	7.53
R67	-	-	-	16	-	-	-	18.500	1.125	1.44	1.38	-	22.30	23.40
R68	18	-	-	-	-	-	-	20.375	0.313	0.56	0.50	-	2.82	2.60
R69*	-	18	-	-	-	-	-	21.000	0.438	0.69	0.63	0.19	4.87	4.74
R70*	-	-	18	-	-	(18)	-	21.000	0.750	1.00	0.94	0.19	11.80	11.64
R71	-	-	-	18	-	-	-	21.000	1.125	1.44	1.38	-	25.20	26.50
R72	20	-	-	-	-	-	-	22.000	0.313	0.56	0.50	-	3.04	2.81
R73*	-	20	-	-	-	21 1/4**	-	23.000	0.500	0.75	0.69	0.13	6.60	6.47
R74*	-	-	20	-	-	(20 3/4)	-	23.000	0.750	1.00	0.94	0.19	12.95	12.75
R75	-	-	-	20	-	-	-	23.000	1.250	1.56	1.50	-	33.30	35.30
R76	24	-	-	-	-	-	-	26.500	0.313	0.56	0.50	-	3.66	3.38
R77	-	24	-	-	-	-	-	27.250	0.625	0.88	0.81	-	11.30	11.10
R78	-	-	24	-	-	-	-	27.250	1.000	1.31	1.25	-	27.10	27.58
R79	-	-	-	24	-	-	-	27.250	1.375	1.75	1.63	0.19	48.70	49.75
R80	22	-	-	-	-	-	-	24.250	0.313	-	0.50	-	-	3.11
R81	-	22	-	-	-	-	-	25.000	0.563	-	0.75	-	-	8.55
R82*	-	-	-	-	-	-	-	2.250	0.438	-	0.63	0.19	-	.508
R84*	-	-	-	-	-	-	-	2.500	0.438	-	0.63	0.19	-	.564
R85*	-	-	-	-	-	-	-	3.125	0.500	-	0.69	0.13	-	.978
R86*	-	-	-	-	-	-	-	3.563	0.625	-	0.81	0.16	-	1.447
R87*	-	-	-	-	-	-	-	3.938	0.625	-	0.81	0.16	-	1.597
R88*	-	-	-	-	-	-	-	4.875	0.750	-	0.94	0.19	-	2.735
R89*	-	-	-	-	-	-	-	4.500	0.750	-	0.94	0.19	-	2.528
R90*	-	-	-	-	-	-	-	6.125	0.875	-	1.06	0.19	-	4.55
R91*	-	-	-	-	-	-	-	10.250	1.250	-	1.50	0.16	-	15.05
R92	-	-	-	-	-	-	-	9.000	0.438	0.69	0.63	-	2.07	2.02
R93	-	26	-	-	-	-	-	29.500	0.750	-	0.94	-	-	16.33
R94	-	28	-	-	-	-	-	31.500	0.750	-	0.94	-	-	17.44
R95	-	30	-	-	-	-	-	33.750	0.750	-	0.94	-	-	18.69
R96	-	32	-	-	-	-	-	36.000	0.875	-	1.06	-	-	26.65
R97	-	34	-	-	-	-	-	38.00	0.875	-	1.06	-	-	28.13
R98	-	36	-	-	-	-	-	40.125	0.875	-	1.06	-	-	29.79
R99*	-	-	-	-	-	-	-	9.250	0.438	-	0.63	0.19	-	2.08
R100	-	-	26	-	-	-	-	29.500	1.125	-	1.38	-	-	-
R101	-	-	28	-	-	-	-	31.500	1.250	-	1.50	-	-	-
R102	-	-	30	-	-	-	-	33.750	1.250	-	1.50	-	-	-
R103	-	-	32	-	-	-	-	36.000	1.250	-	1.50	-	-	-
R104	-	-	34	-	-	-	-	38.00	1.375	-	1.63	-	-	-
R105	-	-	36	-	-	-	-	40.250	1.375	-	1.63	-	-	-

\* Denotes ring number specified in API 6A.

Nominal Pipe Sizes marked\*\* apply to class rating 2000 only.

Nominal Pipe Sizes in brackets apply to class rating 3000 only.

† Ring no. R30 is suitable for lapped flanges only.



## STYLE RX

The Style RX is an adaptation of the standard Style R which energizes on assembly. The RX is designed to fit the same groove design as a standard Style R, making the joints interchangeable.

Consideration should be given to the difference in finished make-up distance.

The modified design uses an energizing on assembly effect which improves the efficiency of the seal.

Designs are also available for Subsea applications.



Style RX

### DIMENSIONAL DATA – STYLE RX

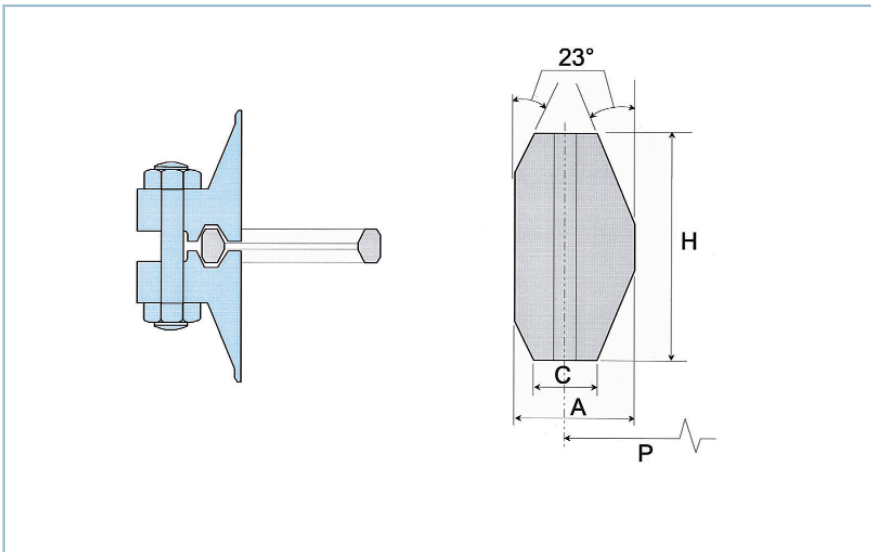

#### TOLERANCES: (INCHES)

A* (width of ring)	+0.008,-0.000
H* (height of ring)	+0.008,-0.000
OD (od of ring)	+0.020,-0.000
23° (angle)	± 1/2°

\*A plus tolerance of 0.008 inches for width 'A' and height 'H' is permitted, provided the variation in width or height does not exceed 0.004 inches throughout its entire circumference.

#### NOTE 1:

The pressure passage hole illustrated in the Ring Type Joint cross section ensures equalization of pressure which may be trapped in the grooves, it is in rings RX82 through RX91 only. Center line of hole shall be located at mid point of dimension "c" (width of flat). Hole diameter shall be as follows:

0.06 inches for rings RX82 through RX85;

0.09 inches for rings RX86 and RX87;

0.12 inches for rings RX88 through RX91.

# STYLE RX

Dimensions in mm

NO.	PRESSURE CLASS RATING (PSI)			PITCH DIAMETER OF RING P	OUTSIDE DIAMETER OF RING OD	WIDTH OF RING A	HEIGHT OF RING H	WEIGHT, lbs.
	2000	3000	5000					
NOMINAL PIPE SIZE (INCHES)								
RX20	–	–	–	68.26	76.20	8.73	19.05	0.527
RX20†	–	–	2 1/16	68.26	76.20	8.73	19.05	0.527
RX23	2 1/16	–	–	82.55	93.27	11.91	25.40	1.15
RX24	–	2 1/16	2 1/16	95.25	105.97	11.91	25.40	1.33
RX25†	–	–	3 1/8	101.60	109.54	8.73	19.05	1.42
RX26	2 9/16	–	–	101.60	111.92	11.91	25.40	1.50
RX27	–	2 9/16	2 9/16	107.95	118.27	11.91	25.40	1.73
RX31	3 1/8	3 1/8	–	123.83	134.54	11.91	25.40	1.91
RX35	–	–	3 1/8	136.53	147.24	11.91	25.40	2.09
RX37	4 1/16	4 1/16	–	149.23	159.94	11.91	25.40	2.27
RX39	–	–	4 1/16	161.93	172.64	11.91	25.40	2.54
RX41	–	–	–	180.98	191.69	11.91	25.40	2.72
RX44	–	–	–	193.68	204.39	11.91	25.40	2.96
RX45	7 1/16	7 1/16	–	211.14	211.93	11.91	25.40	3.66
RX46	–	–	7 1/16	211.14	222.25	13.49	28.58	8.56
RX47	–	–	–	228.60	245.27	19.84	41.28	3.79
RX49	9	9	–	269.88	280.59	11.91	25.40	5.36
RX50	–	–	9	269.88	283.37	16.67	31.75	4.56
RX53	11	11	–	323.85	334.57	11.91	25.40	6.45
RX54	–	–	11	323.85	337.34	16.67	31.75	5.36
RX57	13 5/8	13 5/8	–	381.00	391.72	11.91	25.40	26.40
RX63	–	–	–	419.10	441.72	26.99	50.80	6.63
RX65	16 3/4	–	–	469.90	480.62	11.91	25.40	9.39
RX66	–	16 3/4	–	469.90	483.39	16.67	31.75	7.52
RX69	–	–	–	533.40	544.12	11.91	25.40	20.14
RX70	–	–	–	533.40	550.07	19.84	41.28	11.63
RX73	21 1/4	–	–	584.20	596.11	13.49	31.75	22.10
RX74	–	20 3/4	–	584.20	600.87	19.84	41.28	0.790
RX82	–	–	–	57.15	67.87	11.91	25.40	0.880
RX84	–	–	–	63.50	74.22	11.91	25.40	0.880
RX85	–	–	–	79.38	90.09	13.49	25.40	1.79
RX86	–	–	–	90.49	103.58	15.08	28.58	1.98
RX87	–	–	–	100.01	113.11	15.08	28.58	3.22
RX88	–	–	–	123.83	139.30	17.46	31.75	2.98
RX89	–	–	–	114.30	129.78	18.26	31.75	6.82
RX90	–	–	–	155.58	174.63	19.84	44.45	17.10
RX91	–	–	–	260.35	286.94	30.16	45.24	3.31
* RX99	–	–	–	234.95	245.67	11.91	25.40	–
RX201†	–	–	1 3/8	46.04	46.04	5.74	11.30	–
* RX205†	–	–	1 13/16	57.15	62.31	5.56	11.10	–
* RX210†	–	–	2 9/16	88.90	97.63	9.53	19.05	–
* RX215	–	–	4 1/16	130.18	140.89	11.91	25.40	–
* RX215†	–	–	4 1/16 x 4 1/4	130.18	140.89	11.91	25.40	–

\* API allows more liberal tolerances on RX 201–215

† Denotes API Ring Type Joint gaskets for segmented flanges for dual completions to API Standard 6A.

Designs are also available for Subsea applications.

# STYLE RX

Dimensions in inches

NO.	PRESSURE CLASS RATING (PSI)			PITCH DIAMETER OF RING P	OUTSIDE DIAMETER OF RING OD	WIDTH OF RING A	HEIGHT OF RING H	WEIGHT, lbs.
	2000	3000	5000					
	NOMINAL PIPE SIZE (INCHES)							
RX20	—	—	—	2.688	3.000	0.344	0.750	0.527
RX20†	—	—	2 1/16	2.688	3.000	0.344	0.750	0.527
RX23	2 1/16	—	—	3.250	3.672	0.469	1.000	1.15
RX24	—	2 1/16	2 1/16	3.750	4.172	0.469	1.000	1.33
RX25†	—	—	3 1/8	4.000	4.313	0.344	0.750	1.42
RX26	2 9/16	—	—	4.000	4.406	0.469	1.000	1.50
RX27	—	2 9/16	2 9/16	4.250	4.656	0.469	1.000	1.73
RX31	3 1/8	3 1/8	—	4.875	5.297	0.469	1.000	1.91
RX35	—	—	3 1/8	5.375	5.797	0.469	1.000	2.09
RX37	4 1/16	4 1/16	—	5.875	6.297	0.469	1.000	2.27
RX39	—	—	4 1/16	6.375	6.797	0.469	1.000	2.54
RX41	—	—	—	7.125	7.547	0.469	1.000	2.72
RX44	—	—	—	7.625	8.047	0.469	1.000	2.96
RX45	7 1/16	7 1/16	—	8.313	8.734	0.469	1.000	3.66
RX46	—	—	7 1/16	8.313	8.750	0.531	1.125	8.56
RX47	—	—	—	9.000	9.656	0.781	1.625	3.79
RX49	9	9	—	10.625	11.047	0.469	1.000	5.36
RX50	—	—	9	10.625	11.156	0.656	1.250	4.56
RX53	11	11	—	12.750	13.172	0.469	1.000	6.45
RX54	—	—	11	12.750	13.281	0.656	1.250	5.36
RX57	13 5/8	13 5/8	—	15.000	15.422	0.469	1.000	26.40
RX63	—	—	—	16.500	17.391	1.063	2.000	6.63
RX65	16 3/4	—	—	18.500	18.922	0.469	1.000	9.39
RX66	—	16 3/4	—	18.500	19.031	0.656	1.250	7.52
RX69	—	—	—	21.000	21.422	0.469	1.000	20.14
RX70	—	—	—	21.000	21.656	0.781	1.625	11.63
RX73	21 1/4	—	—	23.000	23.469	0.531	1.250	22.10
RX74	—	20 3/4	—	23.000	23.656	0.781	1.625	0.790
RX82	—	—	—	2.250	2.672	0.469	1.000	0.880
RX84	—	—	—	2.500	2.922	0.469	1.000	0.880
RX85	—	—	—	3.125	3.547	0.531	1.000	1.79
RX86	—	—	—	3.563	4.078	0.594	1.125	1.98
RX87	—	—	—	3.938	4.453	0.594	1.125	3.22
RX88	—	—	—	4.875	5.484	0.688	1.250	2.98
RX89	—	—	—	4.500	5.109	0.719	1.250	6.82
RX90	—	—	—	6.125	6.875	0.781	1.750	17.10
RX91	—	—	—	10.250	11.297	1.188	1.781	3.31
* RX99	—	—	—	9.250	9.672	0.469	1.000	—
RX201†	—	—	1 3/8	1.813	2.026	0.226	0.445	—
* RX205†	—	—	1 13/16	2.250	2.453	0.219	0.437	—
* RX210†	—	—	2 9/16	3.500	3.844	0.375	0.750	—
* RX215	—	—	4 1/16	5.125	5.547	0.469	1.000	—
* RX215†	—	—	4 1/16 x 4 1/4	5.125	5.547	0.469	1.000	—

\* API allows more liberal tolerances on RX 201–215

† Denotes API Ring Type Joint gaskets for segmented flanges for dual completions to API Standard 6A.

Designs are also available for Subsea applications.



## STYLE BX

The Style BX energized Ring Type Joints, manufactured in accordance with API 6A, are designed for use on pressurized systems up to 20,000 psi.

When correctly fitted, the style BX gasket allows virtual face to face contact of the flange faces which means that the gasket is fully trapped on both the inner and outer diameters.

All BX gaskets incorporate a pressure balance hole to ensure equalization of pressure which may be trapped in the grooves.

Designs are also available for Subsea applications.



Style BX

### DIMENSIONAL DATA – STYLE BX

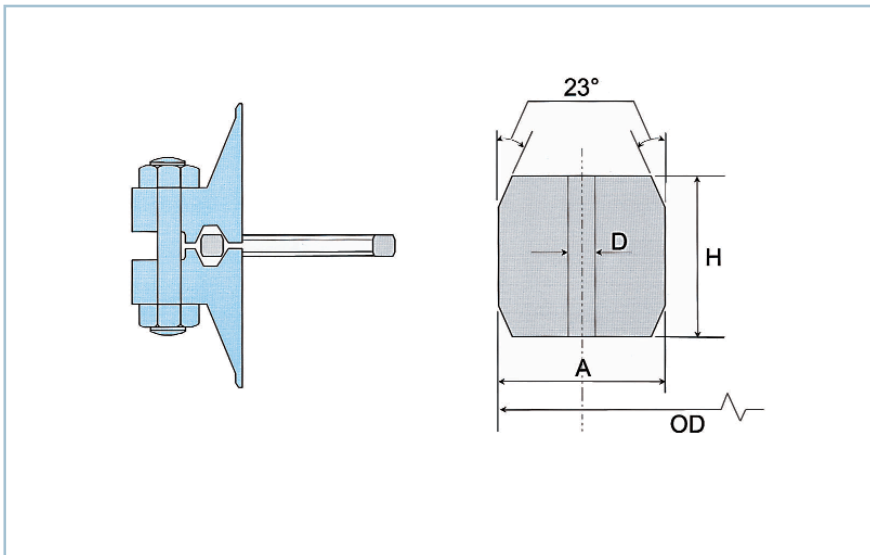

### TOLERANCES: (INCHES)

A* (width of ring)	+0.008,-0.000
D (hole size)	± 0.02
H* (height of ring)	+0.008,-0.000
OD (od of ring)	+0.000,-0.005
23° (angle)	± 1/4°

One pressure passage hole required per ring on center line \*A plus tolerance of 0.008 inches for width 'A' and height 'H' is permitted, provided the variation in width or height does not exceed 0.004 inches throughout its entire circumference.

#### NOTE 1:

Radius of the ring shall be 8% to 12% of the ring height 'H'.

## STYLE BX

Dimensions in mm

RING NO.	PRESSURE CLASS RATING (PSI)				OUTSIDE DIAMETER OF RING OD	HEIGHT OF RING H	WIDTH OF RING A	HOLE SIZE D	GASKET WEIGHT, lbs. FOR API 6BX FLANGES
	5000	10000	15000	20000					
	NOMINAL PIPE SIZE (INCHES)								
BX150	–	–	–	–	72.19	9.30	9.30	1.59	0.295
BX151	–	1 13/16	1 13/16	1 13/16	76.40	9.63	9.63	1.59	0.337
BX152	–	2 1/16	2 1/16	2 1/16	84.68	10.24	10.24	1.59	0.425
BX153	–	2 9/16	2 9/16	2 9/16	100.94	11.38	11.38	1.59	0.632
BX154	–	3 1/16	3 1/16	3 1/16	116.84	12.40	12.40	1.59	0.875
BX155	–	4 1/16	4 1/16	4 1/16	147.96	14.22	14.22	1.59	1.22
BX156	–	7 1/16	7 1/16	7 1/16	237.92	18.62	18.62	3.18	4.14
BX157	–	9	9	9	294.46	20.98	20.98	3.18	6.55
BX158	–	11	11	11	352.04	23.14	23.14	3.18	9.60
BX159	–	13 5/8	13 5/8	13 5/8	426.72	25.70	25.70	3.18	14.41
BX160	13 5/8	–	–	–	402.59	23.83	13.74	3.18	6.75
BX161	16 3/4	–	–	–	491.41	28.07	16.21	3.18	–
BX162	16 3/4	16 3/4	16 3/4	–	475.49	14.22	14.22	1.59	–
BX163	18 3/4	–	–	–	556.16	30.10	17.37	3.18	–
BX164	–	18 3/4	18 3/4	–	570.56	30.10	24.59	3.18	–
BX165	21 1/4	–	–	–	624.71	32.03	18.49	3.18	–
BX166	–	21 1/4	–	–	640.03	32.03	26.14	3.18	–
BX167*	–	–	–	–	759.36	35.87	13.11	1.59	–
BX168†	–	–	–	–	765.25	35.87	16.05	1.59	–
BX169**	–	–	–	–	173.51	15.85	12.93	1.59	–
BX170	–	–	–	–	218.03	14.22	14.22	1.59	–
BX171	–	–	–	–	267.44	14.22	14.22	1.59	–
BX172	–	–	–	–	333.07	14.22	14.22	1.59	–
BX303††	–	–	–	–	852.75	37.95	16.97	1.59	–

\* BX167 is suitable for 26 3/4 Nominal Pipe Size 2,000 psi rating.

\*\* BX169 is suitable for 5 3/4 Nominal Pipe Size 10,000 psi rating.

† BX168 is suitable for 26 3/4 Nominal Pipe Size 3,000 psi rating.

†† BX303 is suitable for 30 Nominal Pipe Size 2,000 and 3,000 psi ratings.

Designs are also available for Subsea applications.

## STYLE BX

Dimensions in inches

RING NO.	PRESSURE CLASS RATING (PSI)				OUTSIDE DIAMETER OF RING OD	HEIGHT OF RING H	WIDTH OF RING A	HOLE SIZE D	GASKET WEIGHT, lbs. FOR API 6BX FLANGES
	5000	10000	15000	20000					
	NOMINAL PIPE SIZE (INCHES)								
BX150	–	–	–	–	2.842	0.366	0.366	0.06	0.295
BX151	–	1 13/16	1 13/16	1 13/16	3.008	0.379	0.379	0.06	0.337
BX152	–	2 1/16	2 1/16	2 1/16	3.334	0.403	0.403	0.06	0.425
BX153	–	2 9/16	2 9/16	2 9/16	3.974	0.448	0.448	0.06	0.632
BX154	–	3 1/16	3 1/16	3 1/16	4.600	0.488	0.488	0.06	0.875
BX155	–	4 1/16	4 1/16	4 1/16	5.825	0.560	0.560	0.06	1.22
BX156	–	7 1/16	7 1/16	7 1/16	9.367	0.733	0.733	0.12	4.14
BX157	–	9	9	9	11.593	0.826	0.826	0.12	6.55
BX158	–	11	11	11	13.860	0.911	0.911	0.12	9.60
BX159	–	13 5/8	13 5/8	13 5/8	16.800	1.012	1.012	0.12	14.41
BX160	13 5/8	–	–	–	15.850	0.938	0.541	0.12	6.75
BX161	16 3/4	–	–	–	19.347	1.105	0.638	0.12	–
BX162	16 3/4	16 3/4	16 3/4	–	18.720	0.560	0.560	0.06	–
BX163	18 3/4	–	–	–	21.896	1.185	0.684	0.12	–
BX164	–	18 3/4	18 3/4	–	22.463	1.185	0.968	0.12	–
BX165	21 1/4	–	–	–	24.595	1.261	0.728	0.12	–
BX166	–	21 1/4	–	–	25.198	1.261	1.029	0.12	–
BX167*	–	–	–	–	29.896	1.412	0.516	0.06	–
BX168†	–	–	–	–	30.128	1.412	0.632	0.06	–
BX169**	–	–	–	–	6.831	0.624	0.509	0.06	–
BX170	–	–	–	–	8.584	0.560	0.560	0.06	–
BX171	–	–	–	–	10.529	0.560	0.560	0.06	–
BX172	–	–	–	–	13.113	0.560	0.560	0.06	–
BX303††	–	–	–	–	33.573	1.494	0.668	0.06	–

\* BX167 is suitable for 26 3/4 Nominal Pipe Size 2,000 psi rating.

\*\* BX169 is suitable for 5 3/4 Nominal Pipe Size 10,000 psi rating.

† BX168 is suitable for 26 3/4 Nominal Pipe Size 3,000 psi rating.

†† BX303 is suitable for 30 Nominal Pipe Size 2,000 and 3,000 psi ratings.

Designs are also available for Subsea applications.



## SPECIALIZED RING TYPE JOINTS

### RUBBER COATED RING TYPE JOINTS

This is an oval Ring Type Joint totally enclosed in a nitrile rubber coating. The Ring Type Joint material is usually soft iron or low carbon steel.

This type of gasket has three main functions:

- It is used in pressure testing to minimize damage to flanges.
- The rubber contact points provide additional seals while protecting the flange surfaces.
- It provides increased assurance against corrosion, which can occur between conventional Ring Type Joints and the engaged surfaces of the groove.

A wide range of standard sizes are available, with special sizes available upon request.



*Rubber Ring Joint*

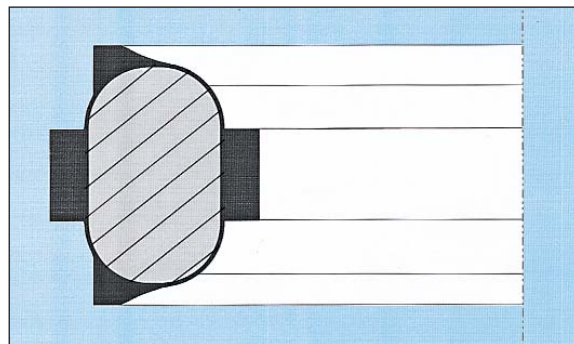

*Section through a Rubber Ring Joint*

### CUSTOM MANUFACTURED SEALS

Flexitallic supplies gaskets, with or without inserts, and other specialized machined metallic components to suit subsea and wellhead equipment.

### BLIND RING TYPE JOINTS

Special Ring Type Joints can be manufactured to blank off flanges and pipework. They consist of standard Ring Type Joints with integral solid metallic centers.

Blind Ring Type Joints can be supplied in all standard materials and exotic alloys.

For further information on the specialized Ring Type Joint products, please contact Flexitallic's Technical Department.

For problematic ring type flange applications, the specialized Flexitallic "CG-RJ" Spiral Wound gasket design may also be considered.



*Special BOP Type Joint*

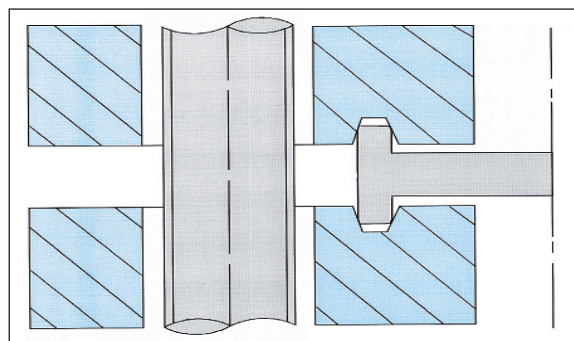

*Section through Blind Ring Type Joint*

## SPECIALIZED RING TYPE JOINTS

For critical and non-standard applications, Flexitallic offers a range of specialized Ring Type Joints to suit the needs of the petrochemical industry.

### TRANSITION RING TYPE JOINTS

These are combination rings which consist of two different sizes having the same pitch circle diameter. They are used for sealing Ring Type Joint flanges where the mating flanges have different ring groove diameters.

Transition Ring Type Joints can be manufactured from standard materials, as well as exotic alloys. Transition Ring Type Joints are available with either oval or octagonal facings and are not encompassed by the API specification.

### SUBSEA GASKETS

Flexitallic is able to provide safe, dimensionally and functionally interchangeable subsea wellhead, mudline and tree equipment within the scope of API.

The performance requirement of pressure integrity, thermal integrity, material choice along with no observable leakage allowable are met with these sealing desires.

To distinguish from topside Ring Type Joints the suffix “s” is used to indicate the additional pressure passage hold in the ring cross section. This is to indicate the additional requirement to prevent pressure lock when connections are made up underwater.

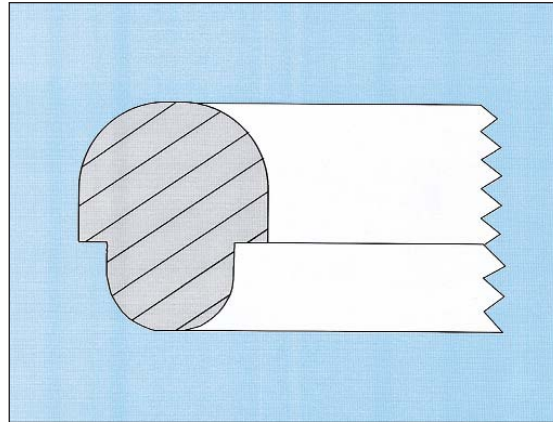

*Transition Ring*

API SBX RTJ

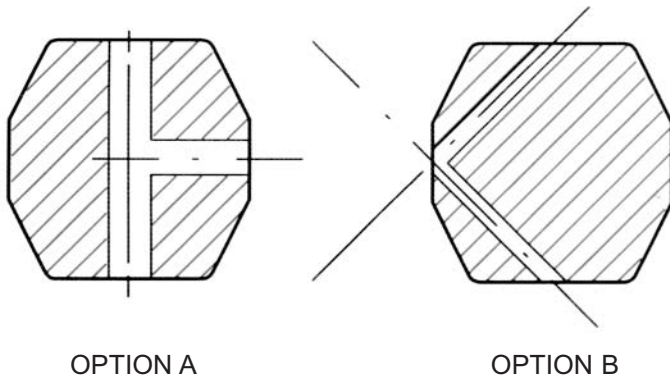

API SRX RTJ

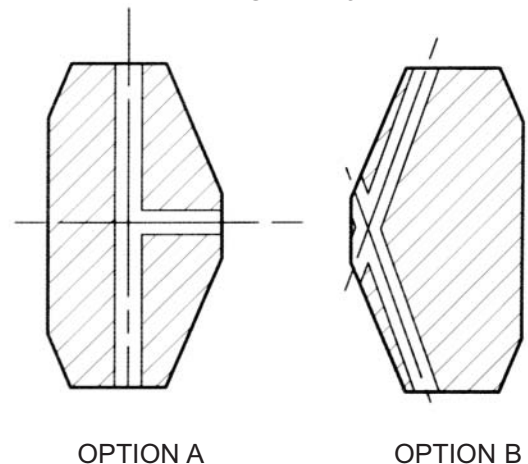

---

## STYLE RX WITH PTFE INSERTS

---

### STYLE RX RING TYPE JOINTS WITH PTFE INSERTS

Style RX Ring Type Joints can also be supplied with PTFE inserts, in order to reduce turbulent flow and eliminate gasket/flange erosion. The insert is specially designed with radially drilled pressure passage holes so that the self energizing performance of the RX Ring Joint is not impaired.

As can be seen right, the insert is located between the inside diameter of the Ring Type Joint and the bore of the flange. On assembly, the insert is completely trapped between the make up of the flanges, filling the annular space between the flange bore and gasket.

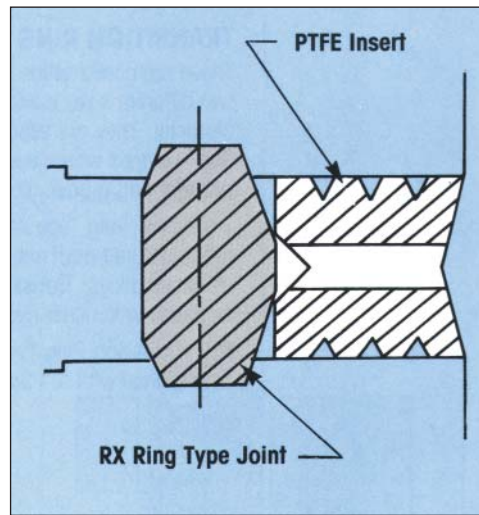

*Section through Oval Ring with Insert*

## WELD RINGS

Another gasket concept, with origins from the German industrial market, is welded gaskets. As standard, two variants exist, Welded Membrane gaskets in accordance with DIN 2695 and Weld Ring gaskets.

### WELDED MEMBRANE GASKETS

The Welded Membrane gasket consists of two similar rings each of 0.157 inch thickness. For chemical compatibility and in order to ensure controlled thermal conductivity and weld compatibility, the gasket material must always be the same as the flange material. Each ring is individually welded to its mating flange and upon flange assembly, a second welding operation ensures the joining of the rings on their outer diameter, thus providing a fully welded joint.

### WELDED RING GASKETS

As with Membrane Welded Gaskets, Weld Ring Gaskets are utilized in pairs. As standard, each ring is 0.591 inches thick and manufactured to similar materials to that of the flange, thus ensuring full compatibility. All welding is conducted on the outside of the outside of the gasket and flange, thus ensuring ease of location, especially in restricted applications where space is of a minimum. Two styles exist, Style SR and Style SRL.

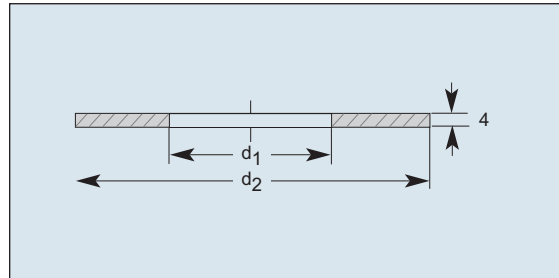

Single Seal Ring

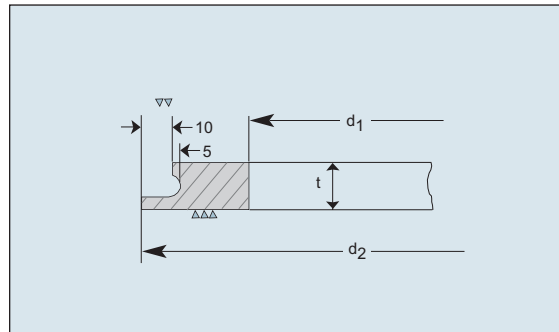

Style SR

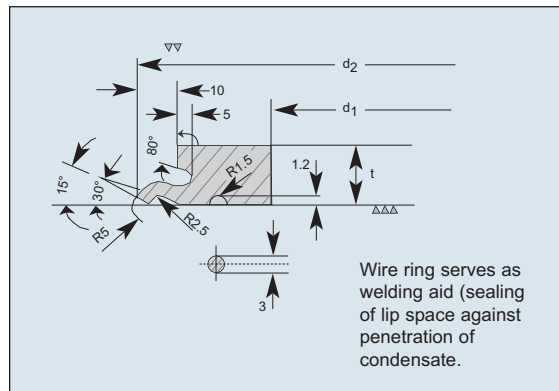

Style SRL



## LENS RINGS

Flexitallic Lens Rings, manufactured in accordance with DIN 2696, provide the engineer with a high integrity, high pressure/temperature seal for special applications.

Lens Rings have a spherical surface and are suitable for use with conical flange faces (other styles are available on request).

As standard, the gasket material should be softer than the flange material, thus ensuring that the applied compressive load leads to the elastic/plastic deformation of the Lens Ring and not the flange sealing face.

By applying higher loads on the gasket the contact area between the Lens Ring and the flange increases. This prevents the gasket from being overstressed.

As with all metallic joints, the re-use of Lens Rings is not recommended. During assembly and use, work hardening of the material occurs. With subsequent re-use, increased bolt loads are required to achieve similar sealing performance. This can lead to damage to the flange faces.



*Lens rings*

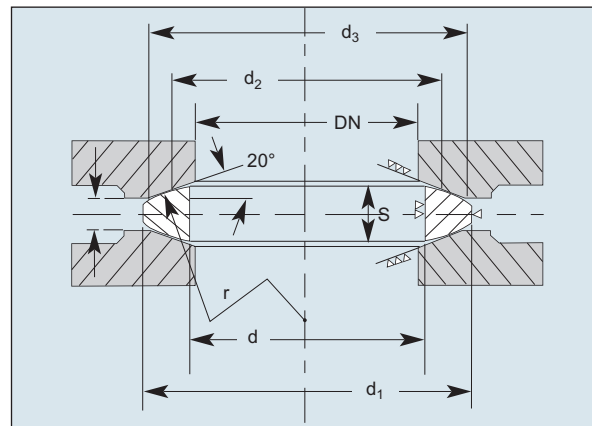

*Cross Section of Lens*

## FLEXITALLIC PRODUCT RANGE



### SPIRAL WOUND GASKET

- Available in a variety of materials for metal winding strip, filler, and guide ring
- Style CG, CGI, R, and RIR
- Meets ASME B16.20 standards
- Class 150 to 2500
- NPS 1/2" to 60"



### SIGMA

- Biaxially orientated PTFE sheet sealing materials
- PTFE sheet materials are available in a variety of forms and levels
- Long term stress retention benefit
- High level of chemical resistance
- Conform to FDA Regulations
- Cryogenic to 500°F (260°C)

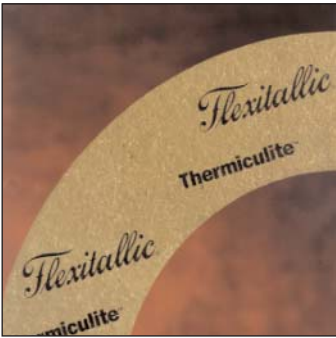

### THERMICULITE

- Will not oxidize, even at temperatures higher than 1800°F (580°C)
- Superb level of tightness even at 930°F (500°C)
- Maximum recommended pressure is 2900 psi
- Available in sheets, spiral wound, Flexpro and LS gaskets



### FLEXPRO GASKET (Kammprofile)

- Precision serrated metallic core with the additions of soft gasket materials
- Suitable from vacuum to Class 2500 and higher
- Suitable from cryogenics to 2000°F (1100°C), depending on core and facing materials



### RTJ GASKETS

- Style R gaskets are manufactured in accordance with both API 6A and ASME B16.20 size/ratings
- Manufactured from fully traceable materials
- Available in both oval and octagonal configurations



### SHEET MATERIALS

- Temperature ranges from ambient to 800°F (425°C)
- Excellent torque retention
- Good chemical resistance
- Wide range of elastomers for chemical compatibility
- Excellent sealability for wide range of chemicals



### HEAT EXCHANGERS

- Metal jacketed gaskets
- Corrugated
- Solid metal
- Metal Reinforced Gasket
- Other engineered gaskets to seal challenging heat exchanger applications



### FLUOROSEAL

- 100% PTFE - inert and resistant to chemicals and corrosive environments
- Chemically resistant 1 - 14 pH range
- Withstands high pressures up to 3000 psi
- Wide temperature range from -400°F (-240°C) to +500°F (260°C)



**DISTRIBUTED BY**

**US PLANT**

Flexitallic L.P.  
6915 Highway 225  
Deer Park, Texas 77536 USA  
Tel: +1 281-604-2400

**EUROPEAN PLANT**

Flexitallic Ltd.  
Scandinavia Mill  
Hunsworth Lane  
Cleckheaton, BD19 4LN England  
Tel: +44 1274 851273

**CHINA PLANT**

Flexitallic Sealing Technology (Suzhou) Co., Ltd.  
Building 3 South  
Wujiang Export Processing Zone  
688 Pangjin Road  
Wuziang, Jiangsu P.R. China 215200  
Tel: +86 512 6303 2839

<http://www.flexitallic.com>

Members of The Flexitallic Group

*Flexitallic*<sup>™</sup>